

# Model 452 PBM THX® Reference THX Powered Subwoofer System

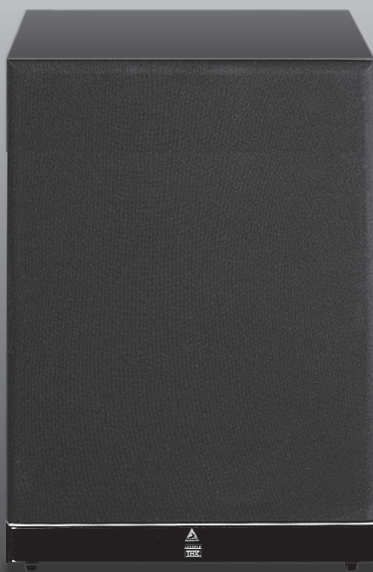

 **Atlantic Technology**<sup>®</sup>  
INNOVATIVE HOME THEATER

343 Vanderbilt Avenue Norwood, MA 02062 (781) 762-6300

*Instruction Manual*

# MODEL 452 PBM THX

## *Reference THX Powered Subwoofer System*

Congratulations on your purchase of an Atlantic Technology 452 PBM THX powered subwoofer. With proper care, your new subwoofer will provide many years of trouble-free, high quality reproduction.

The 452 PBM is fully THX certified to provide very high output levels and a wide dynamic range with smooth in-room response down to 20 Hz, with a peak SPL of 110 dB.

The subwoofer also features a proprietary class G linear amplifier conservatively rated at 325 watts rms. This amplifier, coupled with a massive 15" high-excursion woofer will deliver very high output levels with minimum distortion.

Your Atlantic Technology powered subwoofer will easily integrate with virtually all other brands of loudspeakers on the market. All inputs and outputs, both line level and high (speaker) level, are designed for optimum signal integrity. The premium quality gold plated connectors and all controls are clearly labeled and versatile in operation. The amplifier has more than ample power and headroom to supply a high fidelity foundation to any audio or home theater system.

## Lucasfilm Home THX

George Lucas and Lucasfilm, creators of the *Star Wars* saga, originated and perfected Home THX, a strict set of standards and guidelines for home theaters, enabling you to reproduce the full sound heard in the finest theaters in your home. When properly followed, these guidelines address and



correct the problems encountered when a film soundtrack is played back in the smaller environment of the home. The Home THX system takes a soundtrack that was mixed and equalized to play back in a large theater and adapts it to reproduce more naturally when experienced in the smaller space of your home.

It is important to realize that THX is not a recording process or a special decoding system. All motion pictures will be reproduced as they were heard in the film studio dubbing stage through the Home THX system, no matter what surround decoding system is used. Whether you are using Dolby Digital (AC-3), DTS, Dolby Pro Logic, or any other system, Home THX will make the experience more natural and lifelike. With the lights down, your intimate home theater environment is transformed into the large acoustic space of a real theater. It's really quite startling how "big" your room will sound when the lights are off and the visual cues of your room size are absent.

## Features

Your Atlantic Technology 452 PBM THX powered subwoofer was engineered using the latest technology and finest components available.

- **High excursion 15" driver in a sealed acoustic suspension cabinet**
- **Class "G" linear power amplifier conservatively rated at 325 watts RMS**
- **Discrete, high current output devices**
- **Working frequency range from 20 Hz to full bypass, (approximately 500 Hz)**

- **Adjustable low-pass filter from 55 Hz to full bypass**  
The slope of this low-pass filter is 18 dB/octave. This allows for flexible integration with most any brand or type of speaker on the market. A subsonic filter is also incorporated to filter out inaudible frequencies that can rob amplifier power.
- **Two line inputs, two line thruputs, and an 80 Hz line level high-pass output**  
The thruputs allow daisy-chaining of multiple subwoofers, or can act as a return path back to the processor. The high-pass outputs send the audio signal, minus the bass frequencies below 80Hz, back to your amplifier and main speakers.
- **Phase inverter toggle switch (0/180 degrees)**  
Allows matching with many systems whose output may be inverse phased.
- **Front panel variable volume control with THX preset position**
- **Automatic standby operation**  
The 7-10 minute turn-off delay features a front panel indicator and a defeat switch.
- **IEC AC power socket**  
Unit comes supplied with a detachable power cord.
- **Heavy duty rocker type power switch**
- **Design and construction meets all UL/CSA European safety requirements**

## Connection

The Atlantic Technology 452 PBM THX Powered Subwoofer is simple to hook up, offering several connection methods for maximum flexibility. Study the system diagrams starting on page 5. Once you have found the example which most closely matches your system, hook up your subwoofer(s) as shown in that diagram.

### Low-Level Connection

For simplicity, we suggest using the low-level (RCA style jacks) subwoofer line out or preamp outputs if your receiver/amplifier has them. Simply connect your subwoofer with high quality shielded cables as shown in the diagrams.

### High-Level Connection

Alternately, you may use the high-level (speaker) inputs. Make sure to match the type and gauge speaker wire used to connect your main speakers.

We recommend that you connect your new 452 PBM THX Powered Subwoofer(s) using high quality wire of 16 gauge or larger. There are many respected manufacturers in the audio industry that specialize in speaker wire and interconnect cables suitable for your new system. We recommend that you consult your local audio/video specialist for more specific information.

**Warning:** *To prevent risk of electrical shock or damage to your equipment, always unplug all component AC cords before proceeding with speaker and component connections! The last step in wiring your system is plugging in the AC cords!*

**Figure 1:**  
Amplifier panel and  
controls for Model  
452 PBM THX



**Example 1:  
Subwoofer  
Line Out/  
Low Level In**

This is the most commonly used system connection for systems with surround sound receivers/processors.

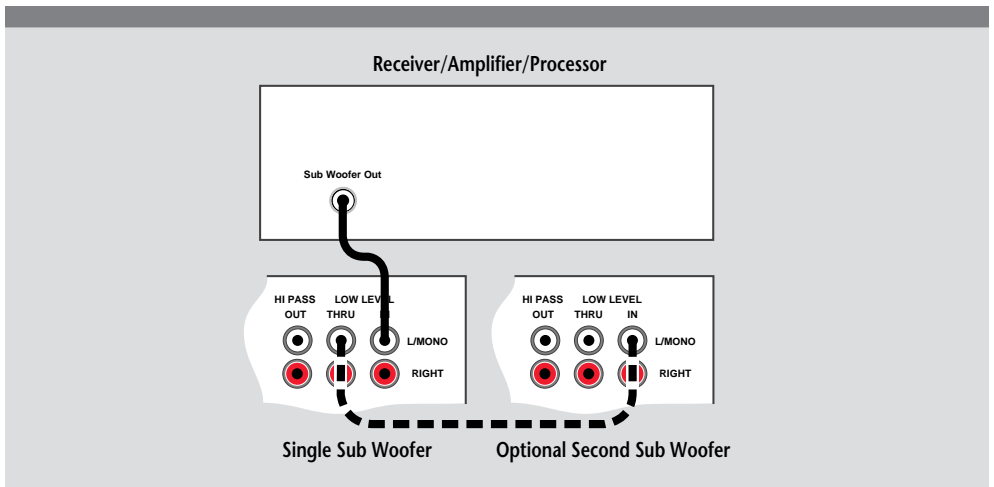

**Example 2:  
Preamp Line  
Out/Low  
Level In for  
1 Subwoofer**

This arrangement is for owners of stereo receivers/amplifiers with Preamp outputs. If your receiver/amplifier uses jumper links between the Pre-out and Main In, then you must remove them and use option 1 or 2. If your receiver/amplifier uses a switch instead of connectors, then use option 3.

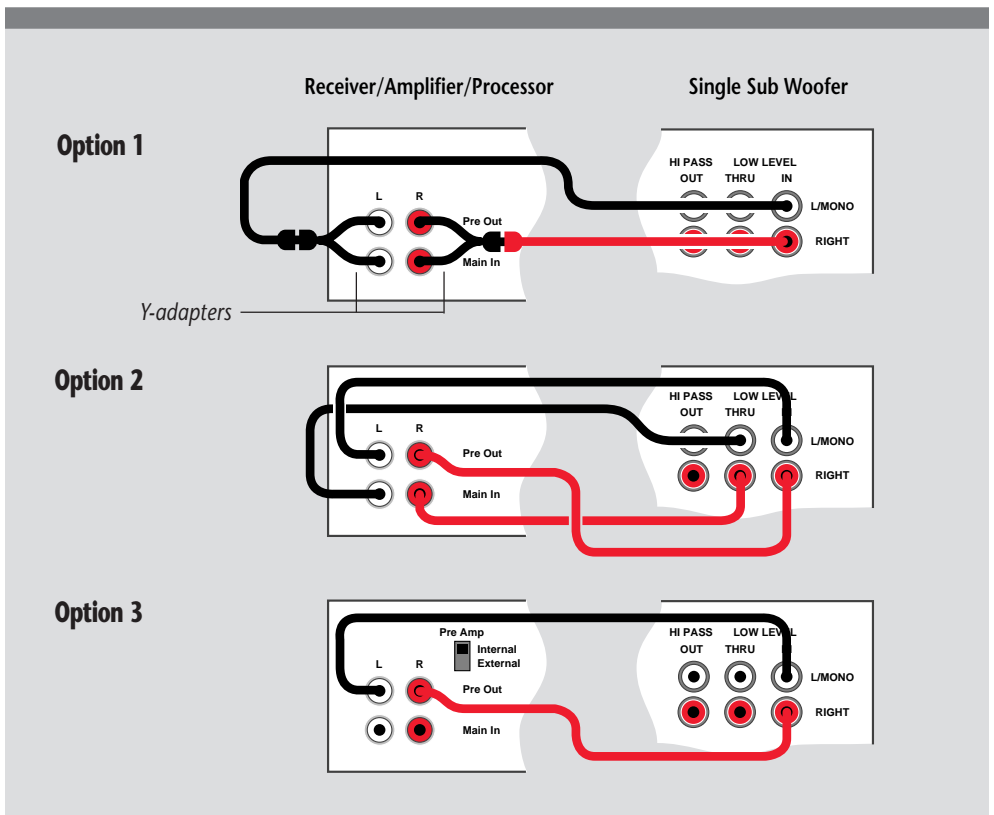

**Example 3:  
Preamp Line  
Out/Low Level  
In for  
2 Subwoofers**

Note that the L/MONO input is used on both subwoofers. Instead of Y-adapters, you may also use the THRU outputs to connect back to the Main Inputs as shown in Option 2 of Example 2.

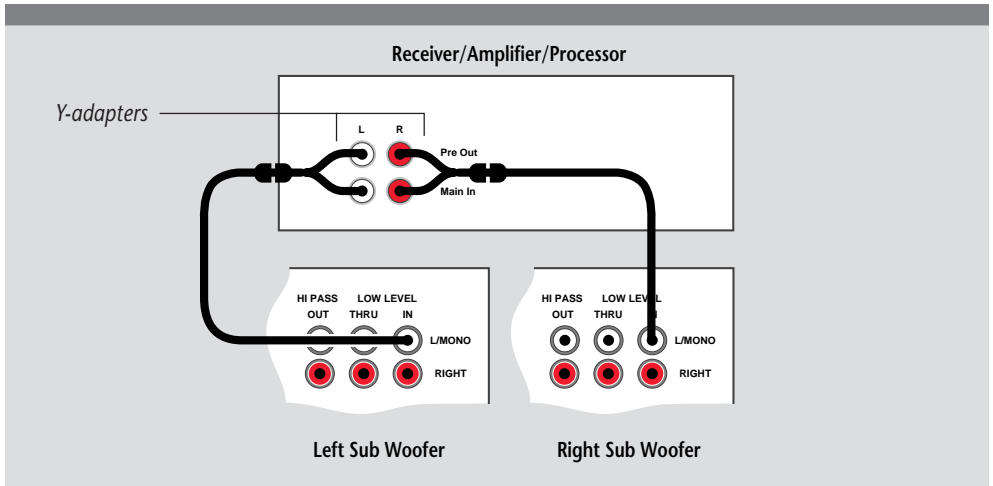

**Example 4:  
Preamp Line  
Out/Low Level  
In using Hi-Pass  
Out for  
1 Subwoofer**

The line level Hi-Pass outputs send audio signals **above** the Lo-Pass filter setting to the main L and R power amplifier inputs. This keeps the low frequencies out of the left and right front speakers, allowing the subwoofers to reproduce the bass frequencies.

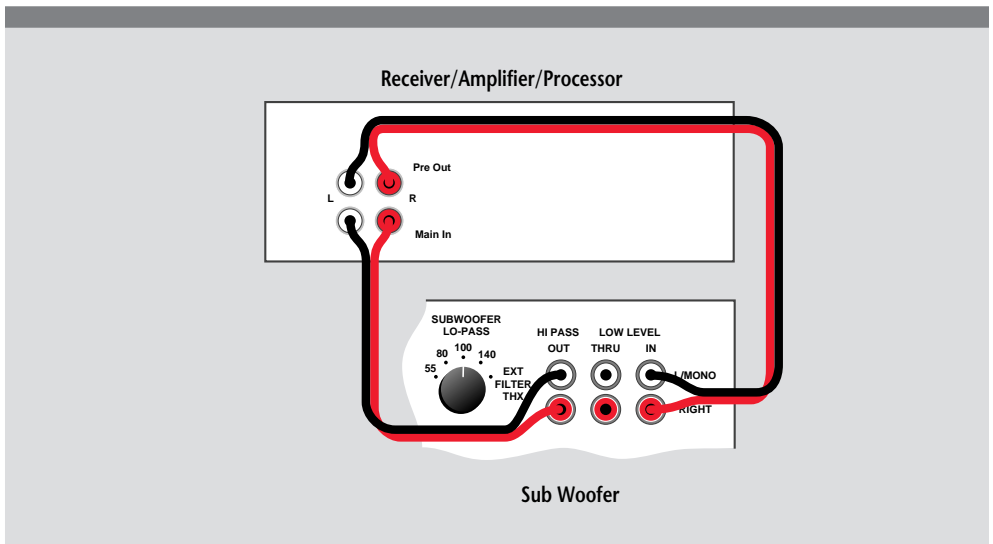

**Note:** These outputs are primarily intended for use in a two channel satellite/subwoofer system where the left and right speakers are small and not designed to reproduce bass. It is also useful when your receiver/amplifier/processor does not internally incorporate a low pass filter.

**Example 5:  
Speaker Out/  
High Level In for  
1 Subwoofer**

This is the most common method for connecting a subwoofer to a system without a dedicated subwoofer line out or Preamp outputs.

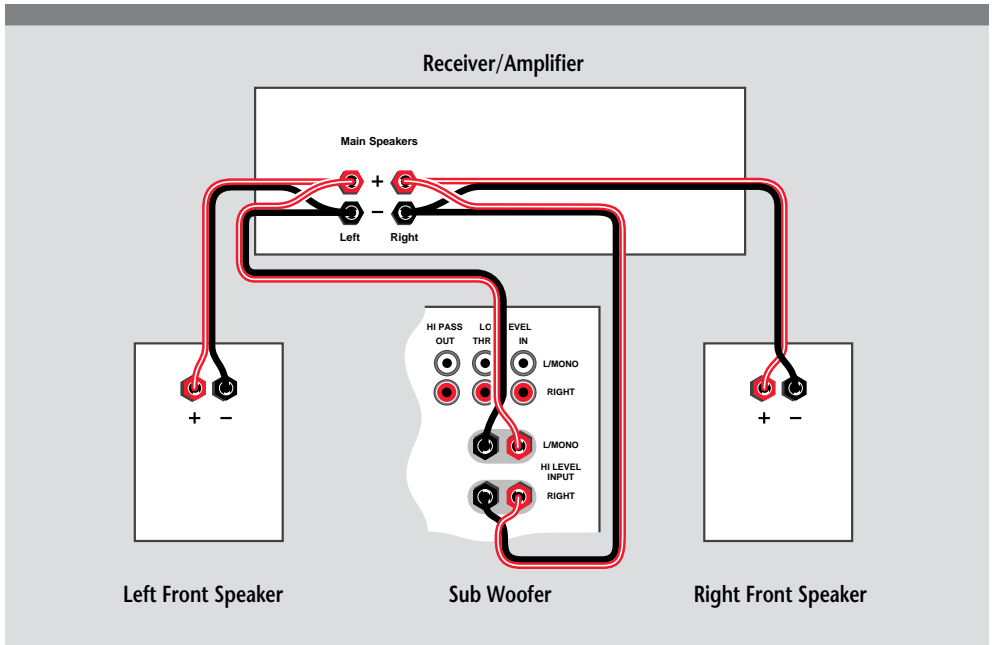

**Example 6:  
Speaker Out/  
High Level In for  
2 Subwoofers**

This is the most common method for connecting 2 subwoofers to a system without a dedicated subwoofer line out or Preamp outputs. Note that the L/MONO High Level input is used on both left and right subwoofers.

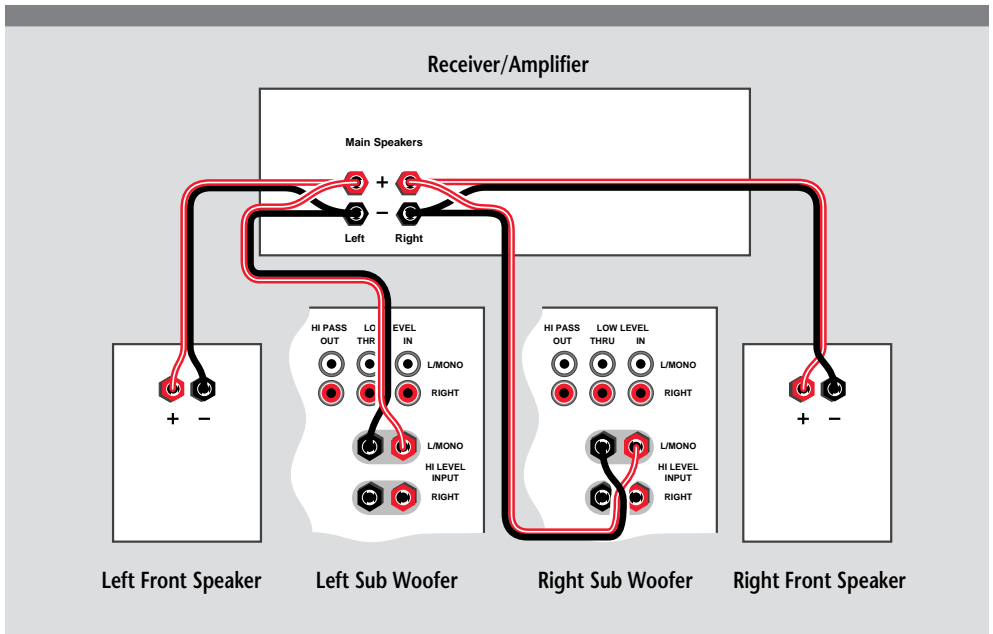

### THX Example: THX Subwoofer Out/Low Level In

Option 1 is the most commonly used method of connecting two subwoofers to a THX system. You may also use a Y-adapter as shown in Option 2.

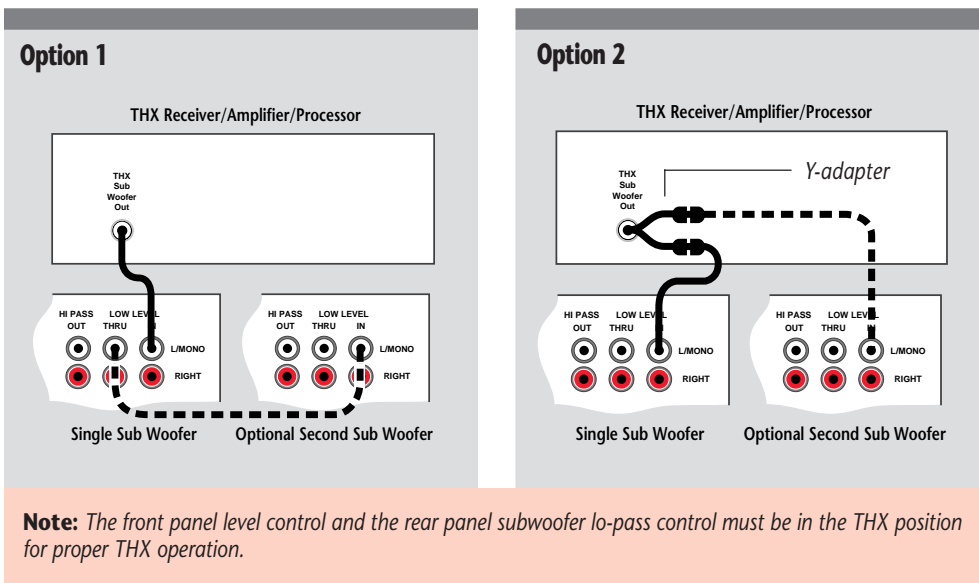

You can connect your 452 PBM THX by using a variety of connectors, or by removing 1/2" of insulation from each wire end, twisting the strands of wire together, placing the wire through one of the post holes and screwing down the nut tightly. We recommend that you check your local electrical codes to make sure you are not using an improper connector.

**Figure 2:**  
Speaker Wiring  
Terminals

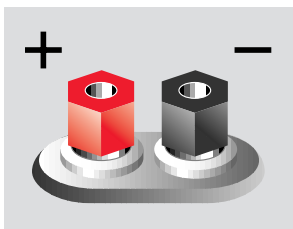

It is important to observe polarity while making speaker connections: red (+) terminals on the amplifier to red (+) on the speaker, black (-) on the amplifier to black (-) on the speaker. Look carefully at the wires you are using and note that one of the wires in each pair is marked by either a different color, printing, ridges, or a thread intertwined with the wire strands. By convention, the marked wire is connected to the red (+) terminal.

### Power Connection

Connect the power cord to an AC outlet only after making all other connections to the subwoofer. This will avoid any chance of accidentally activating the subwoofer while wiring. The AC cord should be plugged into its own wall outlet or into a quality power strip. Avoid using a switched outlet on the rear panel of another component. The subwoofer can draw more current than these outlets can provide and performance will suffer. Once the subwoofer is hooked up and the power switch is turned on, leave it on. The automatic on/off circuitry will only activate the subwoofer in the presence of an audio signal from your audio/video system. After 7-10 minutes with no signal detected from the rest of the system, the amplifier will shut itself off and go into standby mode. When an audio signal is present, the power LED will glow green. Power consumption in the standby mode is negligible.

**Figure 3:**  
The fuse is located next to the IEC AC socket

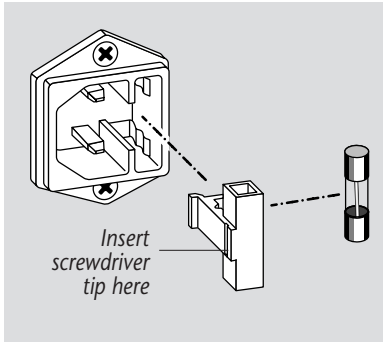

### Changing the Fuse

To change the fuse, remove the power cord, insert a screwdriver tip into the notch in the side of the fuseholder, and pry it out. Replace with the correct value fuse and push back into place. Fuse values are marked adjacent to the IEC AC socket.

## Placement and Operation

The Model 452 PBM THX Powered Subwoofer should be placed in the front of the room, close to a corner (Figure 4). Every room has its own unique sound, and flexibility in the exact placement of the subwoofer is always desirable. In general, the closer the woofer is placed to a corner, the more bass response you will hear. However, in many rooms, corner placement can produce too much bass and the subwoofer will work best well away from the corner. Experiment to find the best position in your room. Refer back to the wiring diagrams starting on page 5 for the correct wiring scheme for your particular setup. Then proceed with listening.

**Figure 4:**  
Typical arrangement for a single subwoofer in a home theater.

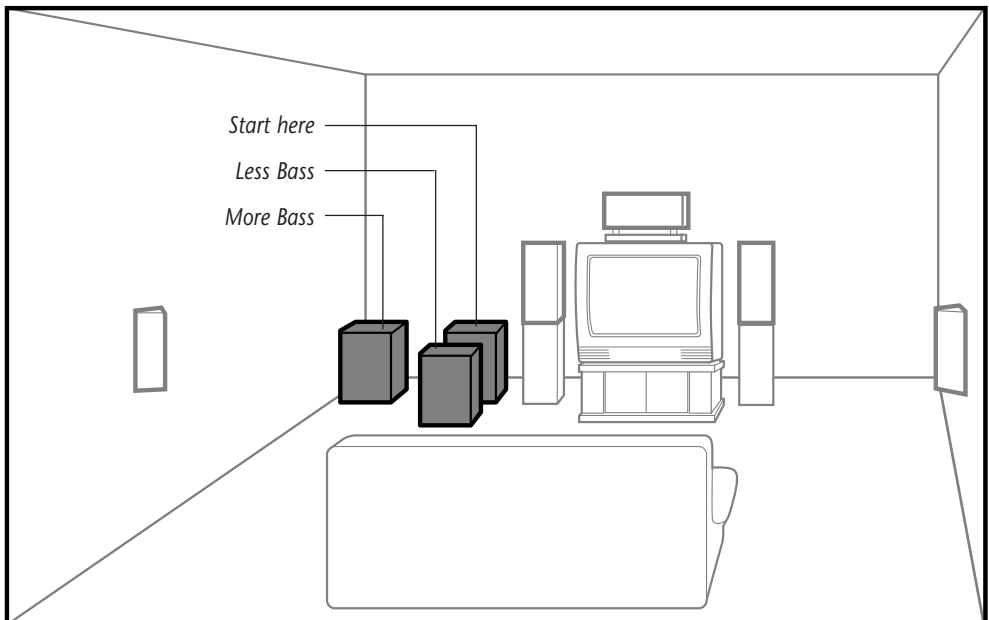

### Subwoofer Tuning—Using the Variable Level Control

Start your listening with the high-pass filter set at 80Hz, the phase switch set to normal, and the front panel variable level control (Figure 5) set to minimum, just above the Fixed THX clickstop position. Play some music that you know has good bass content, and turn the level control up until you just start to hear the subwoofer working. Now, from your normal listening position, determine whether the subwoofer is playing loud enough and filling in the bass frequencies of the music evenly. If it needs adjustment, change the setting of the front panel level control to compensate.

**Figure 5:**  
Front Panel  
Variable Level  
Control located  
behind the  
removable grille



If the bass seems too heavy, move the subwoofer away from the corner. If the bass seems too thin, move the subwoofer closer to the corner. Small differences in positioning the subwoofer can make big differences in the overall bass response. When you

find a position that seems to work well, try switching the phase switch between its two settings, listening closely for the smoothest bass response. **Remember, the most common error is to play the subwoofer too loudly.**

When two subwoofers are used, whether for Home THX operation, regular Dolby Pro Logic, Dolby Digital AC-3, or DTS, they should be placed asymmetrically; that is, in slightly different positions on each side of the television (Figure 6). This will help to attenuate room resonances that are common to symmetrically positioned subwoofers.

**Figure 6:**  
Asymmetrical  
arrangement for  
2 subwoofers in  
a home theater,  
for example, one  
closer to a corner  
than the other

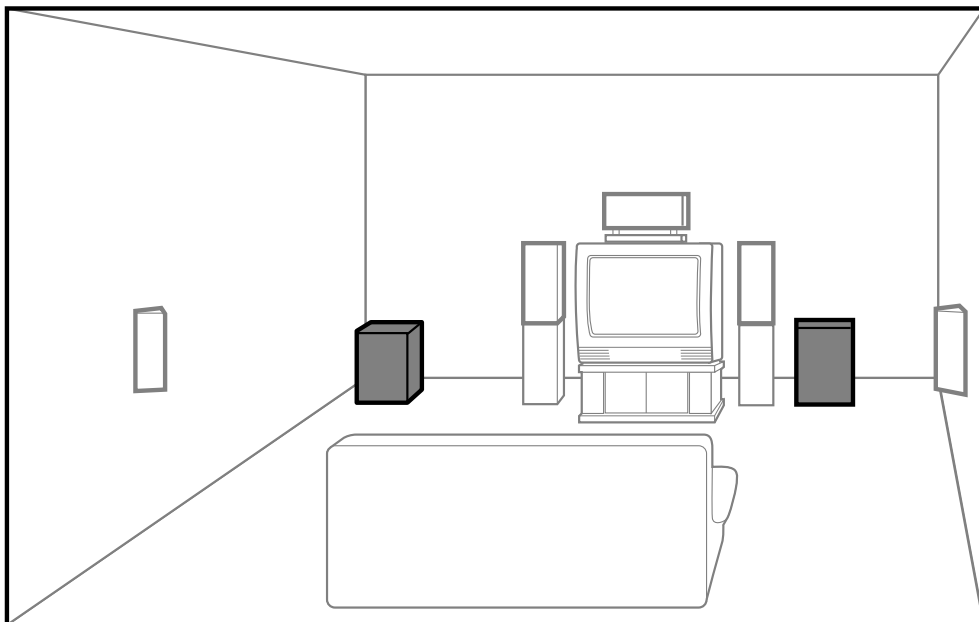

### THX Settings

When using the 452 PBM THX in a system employing THX electronics, both the lo-pass filter on the rear panel and the variable level control on the front panel should be set in the THX position for proper operation. Rotate the variable level control fully counterclockwise until it clicks into the Fixed THX position. This is the preset THX level, but you may increase the setting of this control to compensate for room acoustics. The THX sound quality will not be compromised.

### The Phase Invert Mode

A subwoofer operating out of phase with the rest of the system will not provide optimum low frequency performance. Also, the correct subwoofer phase can enhance room acoustics. Since there is so much variation in the industry regarding phase, and no standards have been established, a switch that will reverse the phase of the subwoofer is provided on the subwoofer amplifier's rear panel. Listen to a monoraul musical source with strong bass content. (For example, you can use the mono switch on an FM tuner or preamp, or use a Y-connector on the outputs of one of your source components to get a mono signal.) Experiment with the position of the phase switch to get the most extended bass. It should be obvious which is the correct setting.

### A Word About Center Channel Modes

Many surround processors and surround receivers feature a “wide” and “normal” mode for the center channel speaker. Atlantic Technology recommends that the center channel be operated in the “normal” mode when using a powered subwoofer. The center channel speaker will sound more dynamic and the intelligibility of the system will generally be improved when in the “normal” mode.

## Subwoofer Troubleshooting Guide

Once your subwoofer is set up, you should have many years of maintenance free enjoyment from your system. However, if you should encounter a problem, refer to the following guide to help you find the solution. If a problem persists, you should contact your local authorized Atlantic Technology dealer.

<b>Problem</b>	<b>Possible Cause</b>	<b>Possible Solution</b>
<b>No bass output</b>	AC power cord unplugged or plugged into a non-working outlet. Input cables not securely connected or defective.	Plug into a working outlet. Check all connections, then try another input cable.
<b>Audible buzz or hum</b>	Input cable not securely connected or defective. Single HI LEVEL input connected to the RIGHT channel only. Ground loop through antenna or cable TV system input.	Check all connections, then try another input cable. Connect to the LEFT input channel. Test by disconnecting antenna and/or cable system input leads. If hum goes away, install isolation balun(s) at that point.
<b>More than one source audible</b>	More than one source is playing.	All the subwoofer's inputs are active at all times. Turn off unwanted source.
<b>Weak bass</b>	Subwoofer too far from the wall. VARIABLE INPUT LEVEL set too low.	Move the subwoofer closer to a wall or corner. Turn control up somewhat.
<b>Weak bass: vague stereo image</b>	Input source connected to HI LEVEL inputs is wired out of phase.	Check speaker wire connections and reconnect in proper phase.

## Model 452 PBM THX Specifications

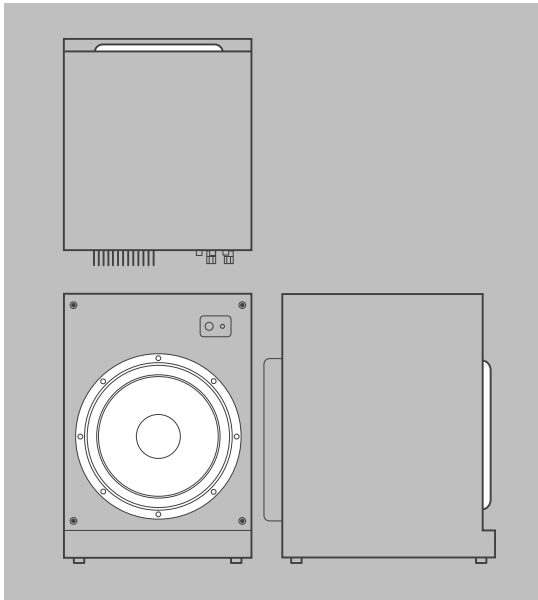

<b>Bass Driver</b>	15 high excursion"
<b>Output Power</b> (rms)	325W
<b>Distortion</b> (amplifier)	0.025%
<b>Frequency Response</b> ( $\pm 3$ dB)	25Hz – 500Hz
<b>Input Impedance</b>	
<b>High Level</b> (speaker)	10k $\Omega$
<b>Low Level</b> (line)	1k $\Omega$
<b>Peak SPL</b>	110dB
<b>Dimensions</b> (W X H X D)	16.75 x 22.625 x 19.625in 425 x 575 x 500mm
<b>Weight</b>	86lbs/39kg
<b>Power Requirements</b>	110V AC 50/60Hz 240V AC 50/60Hz

*Specifications are those in effect at the time of printing. Atlantic Technology reserves the right to change specifications or designs at any time without notice. THX and Lucasfilm are registered trademarks of Lucasfilm Ltd. Dolby Digital, AC-3, Dolby Stereo and Dolby Pro Logic are trademarks of Dolby Laboratories Licensing Corporation. DTS is a registered trademark of Digital Theater Systems, Inc.*

## For Future Reference

Record your speaker serial number and date of purchase here:

Model Number \_\_\_\_\_ Serial Number \_\_\_\_\_ Date of Purchase \_\_\_\_\_

The serial number is found on the back of the speaker near the connecting terminals.



**CAUTION:** To reduce the risk of electric shock, do not remove the cover (or back). No user serviceable parts inside. Refer to qualified personnel.

**WARNING:** To reduce the risk of fire or electric shock, do not expose this appliance to rain or moisture.



The lightning flash with arrowhead, within an equilateral triangle, is intended to alert the user to the presence of uninsulated "dangerous voltage" within the product's enclosure that may be of sufficient magnitude to constitute a risk of electrical shock to persons.



The exclamation point within an equilateral triangle is intended to alert the user to the presence of important operating maintenance (servicing) instructions in the literature accompanying the appliance.