

IWTS-30 LCR THX Ultra2
High Performance In-Wall Theater System Speaker



Atlantic
TECHNOLOGY

Instruction Manual

Table of Contents

- 2 Model IWTS-30 LCR**
- 2 What's THX?**
- 2 Important Considerations Before Installation**
 - 2 Recommended Wire Sizes
 - 2 Location Considerations
 - 3 Room Acoustics
- 3 Speaker Placement**
 - 3 Using the 30 LCR's Tilttable M-T-M Baffle
 - 3 Stereo Music Listening
 - 4 Home Theater Systems
- 5 Installation of the IWTS-30 LCR in Existing Construction**
- 5 Installation of the IWTS-30 LCR in New Construction with Optional Back Box**
- 5 Installation of the IWTS-30 LCR in New Construction without Back Box**
 - 5 Removing and Installing the Grille
 - 5 Cutting the Opening
 - 6 Installing the Mounting Frame
 - 6 Painting the Speaker Assembly
 - 6 Speaker Connection and Assembly
 - 6 Installing the Speaker Enclosure Into the Frame
- 7 Front Panel Controls**
 - 7 HF (High Frequency) Level Control
 - 7 Location Control
 - 7 Boundary Compensation Control
 - 7 IR Knockout
- 7 Specifications**

For Future Reference

Record your serial numbers and date of purchase here:

Model Number _____

Serial Number _____

Date of Purchase _____

The serial number is found on the back panel.

Copyright © 2007 Atlantic Technology International.

Specifications are those in effect at the time of printing. Atlantic Technology reserves the right to change specifications or designs at any time without notice.

Model IWTS-30 LCR In Wall Theater System Speaker

Thank you for purchasing Atlantic Technology products. Our speaker systems have been designed to deliver exceptional sound and value. We hope you like what you hear from them, and are happy with your decision to buy them.

Please take a few moments to read these instructions. They're intended not only to tell you how to mount the speakers, but how to get the best performance from them.

What's THX?

THX is a series of standards and technologies originally developed by LucasFilm Ltd. (of Star Wars fame) and now an entity unto itself. These technologies and standards are intended to ensure that what you hear and see on your A/V system, as closely as possible, matches what the director/artist/engineer heard and saw during the final mixing of the source material. THX standards are intended to enhance every type of viewing and listening experience including the latest discrete multi-channel digital formats. Please note however that, although there is proprietary THX electronic processing, THX is not a surround format.

THX Ultra2 standards are based on a 3000 cubic foot room (L x W x H = cu. ft.). This does not mean Ultra2 certified components must be used in rooms this exact size. The room sizes simply provide a frame of reference, as the standards specify that the system must deliver certain performance minimums (volume, frequency response, etc.) in the specified space. For more information, see the THX website at www.thx.com.

Important Considerations Before Installation

Recommended Wire Sizes

The longer the wire run, the heavier the wire should be. Use the following recommendations as a guide for your installation. And if you're in doubt, remember that it never hurts to get the next heavier grade of wire. Also note that lower gauge numbers equal heavier wire sizes.

Wire Run Wire Gauge:

- <15 ft. 16 ga.
- 15 to 30 ft. 14 ga.
- >30 to 50 ft. 12 ga.

Location Considerations

A major determinant of any speaker's sound quality is its location in the room. With in-wall speakers there are fewer placement options than with free-standing speakers, so giving some thought to location can really pay off. The IWTS-30 LCR has been designed to minimize the detrimental effects wall mounting can have on sound, so they sound better than conventional in-wall speakers.

Room Acoustics

Hard surfaces create lots of sound reflections in the room while soft surfaces tend to absorb sound. Note the speakers' location in terms of proximity to glass and other highly sound reflective or absorptive surfaces. A simple set of curtains or an area rug can make a major difference in sound quality and intelligibility by reducing excessive reflections.

Speaker Placement

For all the following situations, it's recommended that you first place small box speakers in the proposed locations, just to get a good idea of how that location will sound. In-wall speakers are tough to move once they're installed!

Using the 30 LCR's Tilttable M-T-M Baffle

The IWTS-30 LCR has a unique tilttable-rotatable M-T-M baffle that lets you direct the sound with unusual precision, exactly where you want it—regardless of the speaker's physical location in the room.

Determine if the IWTS-30 LCR is going to be mounted horizontally or vertically. If it will be mounted horizontally, the M-T-M baffle should be rotated 90° to maintain the proper vertical orientation of the midranges and tweeter, which is essential for the speaker to deliver its THX-certified performance.



IMPORTANT: Rotate the baffle before the speaker is installed in the wall.



M-T-M baffle can be rotated 90 degrees from center. Do not exceed this rotation angle to avoid putting undue stress on the midrange-tweeter lead wires.

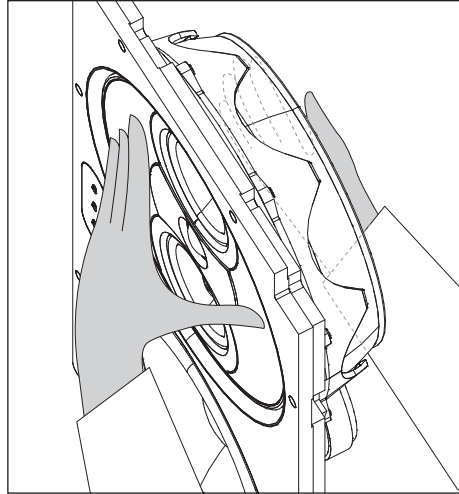

To rotate the baffle, hold the baffle on the front and rear flat surfaces (being careful not to press on the midrange or tweeter diaphragms) and turn the M-T-M baffle to its desired position. Do not exceed 90° of rotation to avoid putting undue stress on the midrange-tweeter lead wires.

The M-T-M baffle may be tilted in any direc-

tion by gently pressing in on the edge of the M-T-M baffle until the desired degree of tilt is achieved. The M-T-M baffle may be tilted either before or after the speaker is installed in the wall.

For all the following placement instructions, it's important to bear in mind that for aesthetic considerations, many people prefer to mount their in-wall speakers well above seated ear level, as doing so minimizes the speakers' visual intrusion on the room.

In those cases, simply angle the 30 LCR's midrange-tweeter baffle down towards the listening area and the 30 LCR's midrange and treble output—which determines both intelligibility and localizability—will be clear and uncompromised, even though the speakers are mounted high up on the walls.

Stereo Music Listening

For stereo music reproduction, place the speakers at approximately ear level when seated, with both speakers on the same wall facing the prime listening location. A separation of approximately 6 to 8 feet between the left and right speakers is usually good. Ideally, the distance between the two speakers will be close to the same as the distance from the speakers to the listening position.

The M-T-M baffle can be "toed in" slightly for better coverage of the listening area.

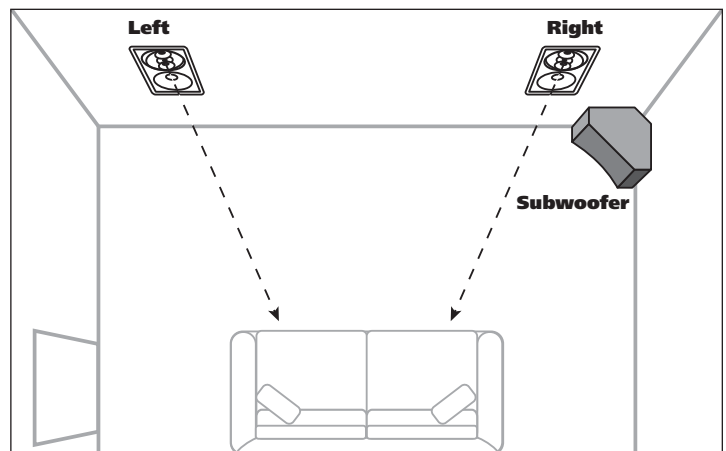

Home Theater Systems

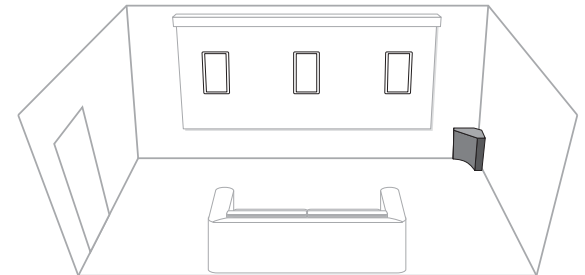
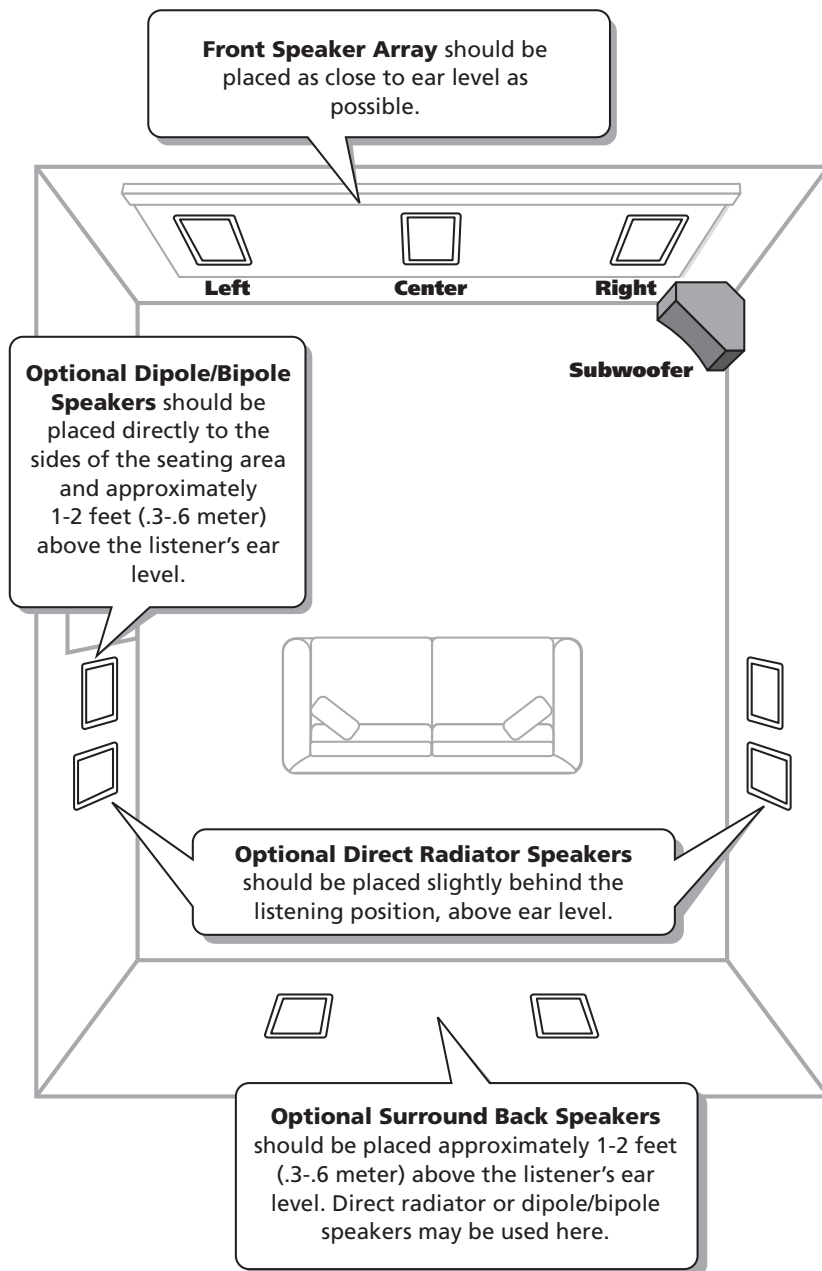

Sometimes, people like to use the Center channel 30 LCR in its horizontal orientation. If so, rotate the MTM baffle 90 degrees so that the midrange-tweeter elements are vertically-oriented. (See page 3 for more info on the tilt-able baffle.)

This ensures the best sound coverage of the listening area, and most importantly, it maintains identical acoustic radiation patterns from all three LCR speakers—critical for the best sound.

The spacing of the left-right speakers can be a little wider than with 2-channel stereo speakers, since in a theater system, the center channel speaker reproduces the on-screen effects and anchors the center image. Left-right spacing of about 8 to 10 feet usually works well.

NOTE: The IWTS-30 LCR is not magnetically shielded. If you are using it with an old-styled CRT-type television, be sure the speakers are located at least 12 inches away from the picture tube to prevent video interference.

Surround Speakers In order to achieve optimum performance, we strongly recommend Atlantic Technology Dipole or TriVector™ surround speakers. If you are using our dedicated surround speakers please follow the placement recommendations included in their installation instructions.

Non-Dipole Surrounds The most realistic surround effects occur when the listener can't localize the actual location of the surround speaker. If you decide to use conventional direct-radiating speakers as surrounds, make sure they don't point directly at the listening area. One good location for direct radiating surrounds is above and slightly behind the listening location, firing straight across the room, or angled slightly towards the rear wall.

Today's home theater systems require you to place six or more speakers in your room. For the most convincing theater effects, speaker placement must be very carefully thought out. This is especially true with in-wall speakers, since their installation is permanent!

Left/Center/Right Locations The front three speakers should be at or just above ear height when seated, just as with stereo speakers. Try to keep the vertical position of the three front tweeters within 18 inches of each other, as this will maintain smooth, believable left-center-right pans.

Installation of the IWTS-30 LCR in Existing Construction

NOTE: We always recommend a professional be involved in the installation of the IWTS-30 LCR.

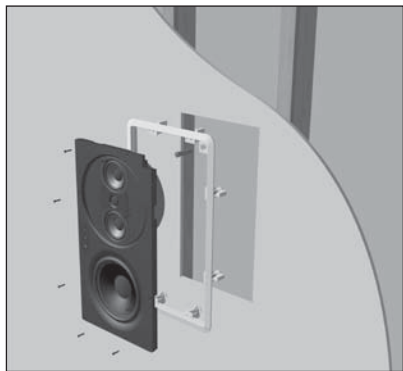

The IWTS-30 LCR can be easily mounted in most any standard wall material, from ½ to 1½ inches thick. Use the grille/frame assembly GFR-626/30, sold separately. The GFR's rotating wall clamps firmly fix it to the wall surface after the proper cutout has been made. An important precaution to take before mounting:

Keep the sides of the actual mounting hole at least 1½ inches away from beams or studs to ensure that the clamps have adequate room to rotate. A stud or other obstruction that's too close will stop them from properly doing their job.

Installation of the IWTS-30 LCR in New Construction with IN-BOX-30LCR Back Box

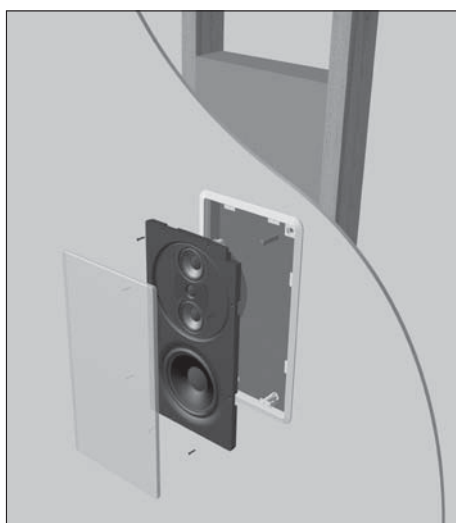

For new construction we highly recommend that you use the IN-BOX-30LCR Back Box. The Back Box provides the correct acoustic environment for the 30 LCR speaker and it is the only way to guarantee that the speaker achieves its THX-certified performance. The rotator clamps (sometimes called "dog legs") will easily grab the combined thickness of ½" sheetrock and the ¾" back box's front panel. The sheetrock must be adhered to the front panel of the back box very solidly and positively. Use very liberal amounts of a high-quality construction adhesive, such as Liquid Nails®, to ensure a secure, vibration-free bond.

Please see the installation instructions that come with the IN-BOX-30LCR for more details.

Installation of the IWTS-30 LCR in New Construction without Back Box

There may be new construction situations where the Back Box IN-BOX-30LCR is either not desired or not feasible. For those situations Atlantic Technology offers an optional Rough-in Frame Kit IN-NC-626/30 to ease installation in new construction. Instructions for its use are included with this kit. Ask your Atlantic dealer for more details.

Important: If the IN-BOX-30LCR is not used in New Construction situations, it's recommended that the wall cavity be treated with acoustic filler and that all extraneous wires, etc. in the wall cavity are securely "buttoned down" so there is no unwanted vibration or rattling after the speaker is installed. Try to make the wall cavity as airtight as possible.

Removing and Installing the Grille

Remove the grille from the speaker using an awl or the point of a drywall screw in a grille opening near one of the grille corners. Slowly pry the grille out, being careful not to damage the speaker's frame or its finish.

To re-install the grille later, press it carefully into the appropriate opening in the frame assembly. Since it's designed to fit snugly, please take your time and use care when installing the grille.

Cutting the Opening

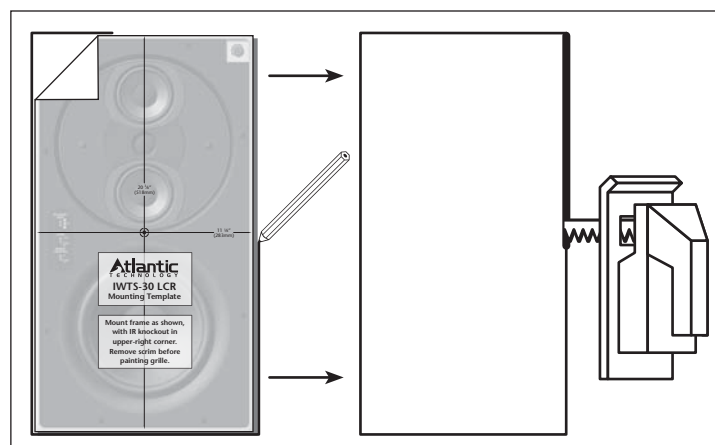

After determining the best location for the speaker as outlined above, use the enclosed template to cut the proper size hole.

11 1/8 x 20 3/8"

WARNING: Exercise extreme care before making any wall cuts to ensure that you will not cut through any wires, pipes, or other items that may be in the wall. You may sometimes, but not always, be able to determine the approximate location of wires and pipes by looking at the locations of nearby outlets and plumbing. But their location or absence is never an assurance that there is not something within the wall cavity.

Installing the Mounting Frame



The clamping mechanism allows the wall material to range from ½ to 1½ inches (13 to 38 mm) in thickness. There must be a minimum depth behind the wall face of 3⅝" (92 mm). As noted above, be sure to keep the edges of the cutout at least 1½ inch (38 mm) away from any stud or obstruction, as the rotating clamps will not operate properly if you don't. The speaker assembly is designed to mount into the white frame, after the frame is mounted into the wall.

Insert the frame into the cutout and using a level or square carefully align it so it is level. Tighten the mounting screws, which will cause the attached clamps to rotate and position themselves properly behind the wall.

Continue to tighten until the frame is snug in the wall. You want the bezel to conform to the wallboard, and the frame not to rattle from the speaker's vibration, **but be very careful not to overtighten the screws.**

It is strongly recommended that you hand-tighten the mounting screws the final few turns (after using an electric screwdriver set to "low torque") to avoid the possibility of damaging the frame.

Painting the Speaker Assembly

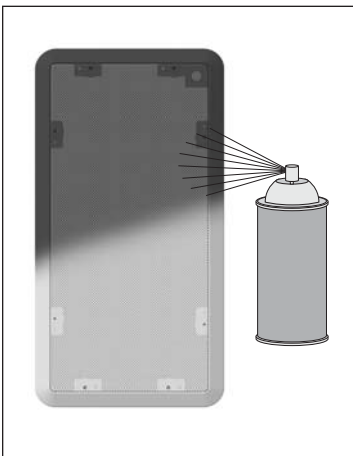

The white plastic frame and the metal grille may be left as is, or painted to match your décor. You can paint the frame before or after it is installed in the wall. Spray painting (using slightly thinned paint) is the best method to use for painting the grille. Before painting, carefully peel off the scrim cloth from inside the grille. After painting the grille, use air pressure to "blow out" any grille holes that are filled in with paint, then carefully replace the scrimcloth.

Speaker Connection and Assembly



Strip about ½" (13 mm) of insulation from the connecting wires. Connect them to the appropriate push terminal, being careful to observe polarity (positive to the red terminal, negative to the black terminal).

Installing the Speaker Enclosure into the Frame

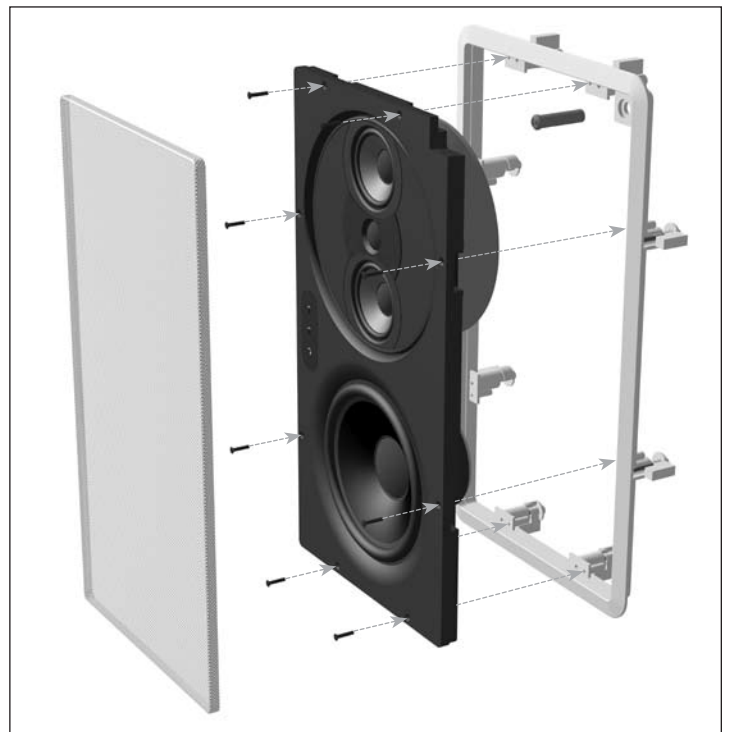

Once the frame is mounted in the wall, the speaker simply fits into the frame. Use the included screws to attach the Baffle to the mounting frame. *The baffle has a gasket around its outside edge to prevent unwanted air leaks, and may therefore fit tightly into the frame. This is normal.*

Use the included screws to attach the baffle to the mounting frame, **but be very careful not to overtighten the screws.**

Front Panel Controls

The IWTS-30 LCR has three controls that help optimize the speaker's performance regardless of mounting location or room acoustics.

High Frequency Level Control



This control adjusts the relative level of high frequency output to compensate for varying room acoustics or placement behind a screen.

“+” is for absorptive, acoustically “dead” rooms (or when the speaker is behind a movie screen). Use this position to increase the HF level and restore the proper sparkle and liveliness to the sound.

“0/THX” is for rooms of average absorptive characteristics.

“-” should be used in rooms that are highly reflective, with hard floors and exposed windows.

The setting of the HF control is mostly a matter of personal taste, so try it in all three positions and see which one is preferred.

Location Control



This control adjusts the relative level of the mid/high frequency output to compensate for placement behind a screen.

“0/THX” delivers the flattest output for placement behind a perforated screen.

“-” reduces the mid-high frequency output slightly.

This control can also be used to adjust for different room acoustics.

Boundary Compensation Control



Large room boundaries, such as floors, walls, and ceilings, reinforce sound by acting essentially as acoustic “mirrors.” When the speaker is mounted too close to the corner or a wall/ceiling intersection, this sonic “reinforcement” often results in an unnatural heaviness or coloration of the sound.

If it's necessary to mount the speaker closer than 12 inches to the ceiling or corner, you may find that by switching the Boundary Compensation control “on,” the speaker sounds better. We recommend that you try the control in both positions and see if it helps in your particular installation.

“On” reduces mid-bass output to compensate for reinforcement of nearby room boundary

“THX/Normal” yields flat response, with no mid-bass cut

IR Knockout



There's an IR “knockout” plug in the upper right corner of the front baffle. If you are using a multi-room control system, you can install a standard IR receiver in the knockout hole.

Should you have any questions or problems please feel free to contact us at 781-762-6300 or through our web site, www.atlantictchnology.com.

Specifications

IWTS-30 LCR	
Type	3-way
Drivers	Woofer 8" (203mm) GLH* Midrange (2) 3½" (89mm) GLH* Tweeter 1" (25mm) soft dome LRT™
Frequency Response	55Hz – 20kHz ±3dB
Nominal Impedance	6 Ohms
Crossover Frequency	500Hz, 3000Hz 3rd order
Sensitivity	89dB
Recommended Power	25 – 200 Watts RMS
Dimensions (grille frame) (W x H x D)	12 5/16 x 21 5/8 x 3 7/8" 312 x 547 x 100mm
Cutout Dimensions (W x H x D)	11 1/8 x 20 3/8" 283 x 518mm
Optimum Sealed Enclosure Volume	1.0 cu. ft.
Net Weight	15lbs; 6.9kg each

*Graphite Loaded Homopolymer

Specifications are those in effect at the time of printing. Atlantic Technology reserves the right to change specifications or appearance at any time without notice.

THX and THX Ultra 2 are trademarks of THX Inc. Manufactured under license from THX Ltd. THX is a trademark of THX Ltd. which may be registered in some jurisdictions. All rights reserved.



343 Vanderbilt Avenue Norwood, MA 02062 (781) 762-6300 www.atlantictechnology.com